

UPS Communicator



Licence for use

The use of the SOFTWARE manufactured by Meta System S.p.A. is completely free of charge.

By proceeding with its installation of his own free will, the USER (an individual or a company) accepts the risks that derive from the installation itself and from the subsequent use of the software programme (the SOFTWARE) and of the relative documentation (the MANUAL).

Guarantee

Meta System S.p.A. does not grant any form of guarantee, whether implicit or explicit, written or verbal, relative to the SOFTWARE or to the components that constitute the same.

The USER takes on all risks that pertain to the use of the SOFTWARE and/or the MANUAL.

Meta System S.p.A. does not declare, guarantee or pledge:

- the quality and/or the performance of the SOFTWARE and/or the MANUAL
- that the functions of the SOFTWARE and/or the MANUAL will satisfy the requirements of the USER
- that the SOFTWARE will operate uninterruptedly
- that the SOFTWARE and/or the MANUAL are without errors or that any problems found may be solved.

Any verbal or written information, assurances or advice offered by Meta System S.p.A., by its resellers, directors, executives, employees, agents or importers do not represent any guarantee.

In no case will Meta System S.p.A., its employees, agents, or any other person involved in the development, the manufacture or the distribution of the SOFTWARE and/or the MANUAL, be responsible for any damages of any kind, including, by way of example, direct or indirect damage, accidental damage or consequential to personal injury, personal property, loss of profit, interruption of activity, loss of information, loss of text or data stored or used with the SOFTWARE, including the cost to restore or reproduce the text or the data or any other loss to property that derives from the use or the impossibility to use this SOFTWARE. This limitation of responsibility also applies should the USER or whoever else have advised Meta System S.p.A. or its authorised representatives of the possibility of such damage, even should the damage be caused or derive from the ordinary, absolute, exclusive or partial negligence on the part of Meta System S.p.A. or of its employees, agents, distributors or associates.

Intellectual ownership rights

Meta System S.p.A. maintains all rights, ownership and interest relative to this SOFTWARE and to the relative manuals (either in paper or electronic format), including rights regarding copyright, registered brands, trademarks, ownership rights, patents, titles, codes and moral rights.

Copyright

The SOFTWARE and the MANUAL are subject to modifications without notice. Meta System S.p.A. does not assume any obligations regarding this information. No part of the SOFTWARE or the MANUAL may be reproduced or transmitted in any form or by any electronic or mechanical means for any reason, without the written authorisation of Meta System S.p.A.

It is expressly forbidden to sell, rent or use the SOFTWARE and/or the MANUAL in any manner for profit.

IT IS FORBIDDEN TO RETROENGINEER, DECOMPILE OR DISASSEMBLE THE SOFTWARE IN ANY WAY

Copyright © 2003, 2005 Meta System S.p.A.

Any names of products present in the SOFTWARE and/or the MANUAL are trademarks registered by the respective companies.

Summary

| | |
|--|----------|
| 1. What is UPS Communicator ? | 6 |
| 1.1. UPS Server..... | 7 |
| 1.2. RS System: Remote Shell System..... | 7 |
| 1.3. UPS Diag Monitor..... | 7 |
| 2. Windows 98 / ME / NT / 2000 / XP / 2003..... | 8 |
| 2.1. Installing UPS Communicator | 8 |
| 2.2. UPS Server Configuration | 9 |
| 2.2.1. "System" Section | 9 |
| 2.2.2. "Shutdown" Section | 10 |
| 2.2.3. "Log & Data" Section | 11 |
| 2.2.4. "Mail Server" Section | 11 |
| 2.2.5. "Events" Section | 12 |
| 2.3. RS System Configuration | 13 |
| 2.3.1. "IP Address" Section..... | 13 |
| 2.3.2. "Scripts" Section | 13 |
| 2.3.3. "LOG File" Section..... | 13 |
| 2.3.4. Advanced Configuration | 14 |
| 2.4. UPS Diag Monitor utilisation..... | 15 |
| 2.4.1. Connecting and disconnecting to a UPS Server..... | 15 |
| 2.4.2. Monitoring the UPS | 16 |
| 2.4.2.1. Information Panel | 16 |
| 2.4.2.2. View Log file | 16 |
| 2.4.2.3. View Data file | 16 |
| 2.4.2.4. Operating data..... | 17 |
| 2.4.2.5. Input Data..... | 17 |
| 2.4.2.6. Output Data..... | 18 |
| 2.4.2.7. Batteries | 19 |
| 2.4.2.8. Hardware Information | 20 |
| 2.4.2.9. Input and Output Sine Waves | 20 |
| 2.4.2.10. UPS History | 20 |
| 2.4.2.11. List of Events | 21 |
| 2.4.3. Scheduling..... | 22 |
| 2.4.4. Send a shutdown command to <computer_name> | 23 |
| 2.4.5. Setting the UPS parameters and functions..... | 23 |
| 2.4.5.1. UPS Setup..... | 23 |
| 2.4.5.1.1. Input..... | 23 |
| 2.4.5.1.2. Output | 24 |
| 2.4.5.1.3. Batteries..... | 24 |
| 2.4.5.1.4. Clock..... | 25 |
| 2.4.5.1.5. Programming..... | 25 |
| 2.4.5.2. Enable Buzzer | 26 |
| 2.4.5.3. Battery test | 26 |
| 2.4.5.4. Autonomy Calibration Test..... | 26 |
| 2.4.5.5. Reset Battery History..... | 26 |
| 2.4.5.6. Reset Events List..... | 26 |
| 2.5. System Shutdown | 27 |
| 2.5.1. UPS Server Script | 27 |
| 2.5.2. RS System Script | 27 |
| 2.6. Utility programmes | 28 |
| 2.6.1. UPS Binder..... | 28 |

| | |
|---|-----------|
| 2.6.2. LOG file viewer | 28 |
| 3. Linux..... | 29 |
| 3.1. Installing UPS Communicator | 29 |
| 3.2. UPS Server Configuration | 30 |
| 3.2.1. "System Configuration" menu | 30 |
| 3.2.2. "Shutdown Configuration" menu | 31 |
| 3.2.3. "Log & Data" menu | 32 |
| 3.2.4. "Mail Server" menu | 32 |
| 3.2.5. "Events Configuration" menu | 33 |
| 3.3. RS System Configuration | 34 |
| 3.3.1. "Authorized IP List" menu | 34 |
| 3.3.2. "Set TCP/IP Listen Port" menu | 34 |
| 3.3.3. "Scripts Files Overview" menu | 34 |
| 3.3.4. "LOG File Configuration" menu..... | 35 |
| 3.3.5. "Advanced Configuration" menu..... | 35 |
| 3.4. UPS Diag Monitor utilisation..... | 36 |
| 3.4.1. Connecting and disconnecting to a UPS server | 36 |
| 3.4.2. Monitoring the UPS ("Read Data" menu)..... | 36 |
| 3.4.2.1. "UPS Info Read" menu | 36 |
| 3.4.2.2. "Main Data Read" menu | 37 |
| 3.4.2.3. "Input Data Read" menu | 37 |
| 3.4.2.4. "Output Data Read" menu..... | 38 |
| 3.4.2.5. "Battery Data Read" menu..... | 39 |
| 3.4.2.6. "Hardware Data Read" menu..... | 40 |
| 3.4.2.7. "UPS History Read" menu | 40 |
| 3.4.2.8. "Event List Read" menu | 41 |
| 3.4.3. Execution of Tests and Actions ("Actions and Test" menu) | 42 |
| 3.4.3.1. "Scheduler" menu | 42 |
| 3.4.3.2. "Battery Test" menu | 42 |
| 3.4.3.3. "Autonomy Calibration Test" menu | 43 |
| 3.4.3.4. "Execute Server Shutdown" menu | 43 |
| 3.4.4. Setting the UPS parameters ("UPS Setup" menu)..... | 43 |
| 3.4.4.1. "Input Data Set" menu | 43 |
| 3.4.4.2. "Output Data Set" menu..... | 44 |
| 3.4.4.3. "Battery Data Set" menu | 45 |
| 3.4.4.4. "Buzzer Set" menu..... | 45 |
| 3.4.4.5. "UPS Clock Set" menu..... | 45 |
| 3.4.4.6. "UPS History Reset" menu..... | 45 |
| 3.4.4.7. "Events List Reset" menu..... | 46 |
| 3.5. System Shutdown | 46 |
| 4. Customisation of messages to users..... | 46 |
| 5. RS232 connection cables..... | 47 |
| 5.1. Harviot 550 | 47 |
| 5.2. Niky 400, 600, 850 | 47 |
| 5.3. Niky 450, 650, 900 | 48 |
| 5.4. Niky 1100, 1500, 1800 | 48 |
| 5.5. All others models..... | 48 |
| 6. F.A.Q..... | 49 |
| 6.1. General Topics | 49 |
| 6.2. Windows | 49 |
| 6.3. Linux | 49 |

7. Customer Service 50

1. What is UPS Communicator ?

UPS Communicator is an application whose main task is to control the operation of the UPS, safeguarding the operating systems of the computers powered by the UPS itself.

Its client/server structure makes it extremely flexible, effective, efficient, simple to use and “undemanding” from the point of view of the system resources it needs.

UPS Communicator’s architecture can be summarized as follows:

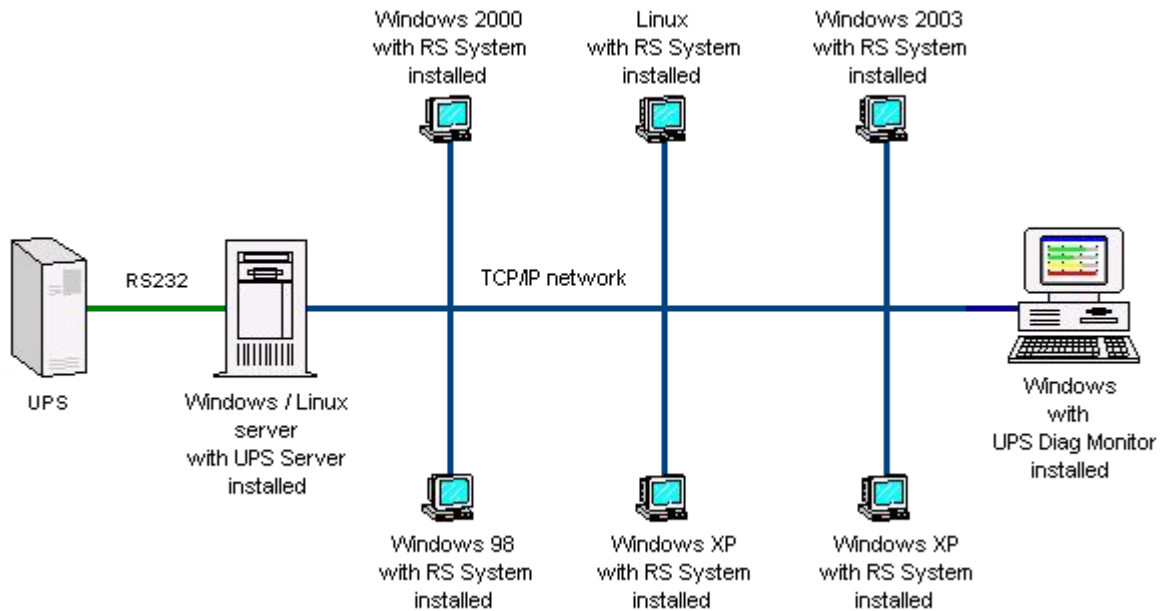

The main software modules that make up *UPS Communicator* are:

- ✓ UPS Server: UPS Server
- ✓ UPS Diag Monitor: Graphic monitoring client
- ✓ RS System: Remote Shell System

1.1. UPS Server

The UPS Server is the main module in all of the application and it runs as a background process. It has the task of receiving and interpreting the information coming from the UPS and of managing the configuration of its special settings and of events that could endanger the operating system in any way where it is installed.

The main actions that it may undertake in case of need are:

- ✓ To record the event and the relative operating data on a Log file
- ✓ To warn operators by means of on-screen messages
- ✓ To send e-mails
- ✓ To execute local programmes
- ✓ To execute the shutdown of the local computer
- ✓ To execute the shutdown of remote computers (together with *RS System*)
- ✓ To execute remote programmes (together with *RS System*)
- ✓ To send messages to the screens of remote operators (together with *RS System*)

The UPS server also make this UPS data available to *UPS Diag Monitor* graphic clients by means of a coded system and TCP/IP protocol so that a full analysis of the UPS' operating status is possible and its operating parameters and special functions, as supported by the UPS itself, can be set.

1.2. RS System: Remote Shell System

When the need arises to install a UPS supplying more than one computer, it naturally leads to the requirement to envisage shutdown of all the computers in question. However, it would be illogical to connect each of these computers to the UPS via a separate RS232 cable.

RS System (**R**emote **S**hell) is a utility which can be installed on a remote computer to enable its automatic shutdown, the displaying of messages or the execution of customised programmes, by way of a command sent by the UPS server installed on the main computer.

In a situation where one of the commands described must be executed, UPS server sends a coded command (exclusively via TCP/IP protocol) to each of the computers where the RS module has been installed. This first verifies the authorisation of the UPS server for the sending of the command itself and then executes a customised script.

RS System can also simply be used for sending popup messages, thus avoiding the problem of the transmission of messages by a Windows 9x computer to another.

1.3. UPS Diag Monitor

UPS Diag Monitor is the tool that makes it possible to display and interact with all the UPS data further to connection to a UPS server (local or remote).

2. Windows 98 / ME / NT / 2000 / XP / 2003

2.1. Installing UPS Communicator

The software is very straightforward to install and does not demand any specific skills: administrator rights are only required for NT platforms (NT, 2000, XP, 2003).

Procedure:

1. Select the language for installation. This affects:
 - The installation programme
 - The software modules installed
 - The help file and documentation
2. Accept the terms of the license
1. Key in a User Name, Organisation and Serial Number (sent to you by e-mail after you register on the website http://www.metasystem.it/ups/communicator/gb_index.htm)
3. Select the destination folder: we recommend you use the suggested default folder unless you have special requirements (C:\Program files\MetaSystem\UPS Communicator\)
4. Select the modules to be installed:
 - UPS Server ("Master" mode): module for UPS management and communications
 - UPS Diag Monitor: module for the display and settings of the UPS parameters
 - RS System (Remote Shell – "Slave" mode): module for the execution of shutdown, messages and remote programmes
 - UPS Binder (Control Panel): the control panel used to access all the modules in the application
 - Documentation (PDF format): this manual
5. Select the folder in the Run/Start menu that will contain the programme's shortcuts (icons).
6. Select whether to install the *UPS Binder* icon (control panel for the application) on your desktop and/or on the quick start bar.
7. Press the "Install" box to start copying the programme file.

When the installation has been completed, the relative configuration programmes will automatically run according to the modules selected. A new folder will be created in the Run/Start menu (default: UPS Communicator) to contain all the shortcuts required.

We recommend you restart your computer at the end of the installation procedure.

2.2. UPS Server Configuration

In order to work correctly, the UPS server requires certain parameters: this information can be set using the configuration programme.

The configuration parameters are divided up into categories that can be selected by clicking on the appropriate boxes located to the left of the main configuration programme window.

After configuration has been completed, you are asked whether to restart the UPS server so that the modifications will become effective immediately, otherwise the modifications will take effect the next time the computer or UPS server is started up.

2.2.1. "System" Section

Accurate setting of these parameters is essential in order to safeguard correct communications with the UPS.

- ❑ **UPS Model**
This specifies the model of UPS interfaced with the computer. Make your selection by clicking on the "Select" box and then choosing the model from the list.
Selecting the UPS model will restore the default settings for the autonomy data and any customised actions set in the "Events" section.
- ❑ **Battery recharge time**
This specifies the total time, in hours, required by the UPS in order to recharge the batteries after they have been completely discharged; it is set automatically when the UPS model is selected.
We recommend leaving the default setting for this parameter unless a more batteries have been fitted than standard or if additional battery chargers have been installed.
- ❑ **Location of UPS / Computer**
This specifies the actual location of the UPS or of the computer that it is interfaced with (for example: EDP room; office 2nd floor; etc...).
- ❑ **Device for communications**
This enables you to specify the computer's serial port (COM) used for connection of the UPS.
- ❑ **TCP/IP listen port**
This is the TCP/IP port used for communications by the UPS server and the UPS Diag Monitor clients. The parameter can be altered should this port already be used by another programme in the system; in this case, however, you must do the same on the monitoring client during the request for connection to the UPS server.
- ❑ **Password for UPS Diag Monitor**
This specifies the password used by the monitoring client in order to access certain special functions, such as UPS set-up, tests and programming of switching off and switching back on. The password is optional.
- ❑ **Frequency of Broadcast Event**
This is the frequency, in seconds, of the actions set for the option "Broadcast event - UPS still in battery mode" to be carried out by the UPS server (these are normally messages to users notifying them of the time that remains before shutdown will start). The event will only be managed if the UPS is operating on battery power, further to an actual mains power failure, and if the "Enable System Shutdown" option has been enabled.

❑ **Install as System Service (optional; default: enabled)**

This specifies the type of usage of the UPS server and, consequently, the method for starting up.

- ✓ *Disabled:* used exclusively as a diagnostics programme for the UPS: does not start up automatically when the computer is started.
- ✓ *Enabled:* used as a control programme for the automatic execution of shutdown: installed as a system service with automatic start up.

2.2.2. "Shutdown" Section

The parameters of this section are needed for the management of UPS autonomy, system shutdown, the switching off and subsequent automatic restarting of the UPS.

❑ **Enable System Shutdown**

Enables or disables the possibility for the UPS server to execute automatic system shutdown.

If the application is used exclusively for UPS diagnostics, we recommend this setting be disabled.

❑ **Type of autonomy management**

This gives you the possibility to manage the autonomy (provided this is permitted by the currently selected UPS) with two different and, in a certain way, opposite methods:

- ✓ *Advanced:* the UPS server uses all the autonomy of the UPS except for the autonomy reserve and the time specified in the parameter *Time required for shutdown*.
- ✓ *Fixed:* shutdown always starts x minutes after the UPS has switched over to battery power.

N.B: shutdown always starts immediately when the autonomy reserve signal has been reached (batteries flat).

❑ **Time needed for system shutdown**

Only visible if "advanced" management of autonomy has been specified. It indicates how long (in minutes) the computer needs to complete its shutdown procedure. If the parameter *Enable UPS shutdown* has been selected, we recommend setting the actual time needed for shutting down the computer plus one extra minute.

❑ **Always execute shutdown after [m] in battery mode**

Only visible if "fixed" management of autonomy has been specified. It indicates how long, in minutes, shutdown of the computer will start after the UPS has switched over to battery power.

❑ **Allow shutdown execution from the UPS Diag Monitor**

This specifies if it is possible to send the computer shutdown command from UPS Diag Monitor.

❑ **Enable UPS shutdown**

This gives you the possibility to enable or disable the automatic switching off of the UPS at the end of computer shutdown. If switch on/switch off scheduling is used (see *UPS Diag Monitor*), this parameter must be enabled.

❑ **Delay from start of system shutdown**

This gives you the possibility to specify after how many minutes the UPS should switch off, starting from the launch of the computer shutdown procedure. If "advanced" management of autonomy has been selected, the minimum amount that can be set is limited so that it is not possible to specify an amount of time below the setting for *Time needed for shutdown* in order to prevent the UPS switching off when the computer shutdown procedure is still running.

❑ **Enable UPS restart**

Enables or disables the automatic switching on of the UPS after mains power has returned.

If switch on/switch off scheduling is used (see *UPS Diag Monitor*), this parameter must be enabled.

❑ **Delay from return of power**

This specifies how many seconds must pass after mains power has returned before the UPS automatically switches after being switched off because of a mains power failure.

2.2.3. "Log & Data" Section

The parameters contained in this section refer to the recording of data by the UPS server.

❑ **Enable recording of LOG file**

Enables or disables the writing on disk of UPS and external events.

❑ **Maximum file size**

This gives you the possibility to specify the maximum size in bytes for the events file. Once this has been reached, the file is deleted and a new one is created.

❑ **Enable recording of DATA file**

Enables or disables the writing on disk of the UPS and mains electricity operating specifications.

❑ **Maximum file size**

This gives you the possibility to specify the maximum size in bytes of the operating specifications file. Once this has been reached, the file is deleted and a new one is created.

❑ **Recording frequency**

This specifies the frequency, in seconds, of the writing of the operating specifications file.

❑ **Selection of values for recording**

This gives you the possibility to select the specifications from a list (input voltage, output voltage, etc...) to be stored in the file.

2.2.4. "Mail Server" Section

This section allows you to adjust the configuration of the programme's options for the sending of e-mails.

❑ **Sender's e-mail address**

This specifies the sender's e-mail address and is used to login to the SMTP server (if authentication is not required).

❑ **Name or TCP/IP address of SMTP server**

Name or IP address of the mail server (SMTP) used to send e-mails.

❑ **Use SMTP authentication**

Enable this parameter if the mail server (SMTP) requires authentication and specify a valid *login* and *password*.

2.2.5. "Events" Section

The parameters in this section control how the UPS server behaves based on UPS or external events. All the events already have default settings for a range of actions relating to the event in question.

❑ **Events list**

This specifies the events managed by the UPS currently selected.
The contents of this list may vary depending on the type of UPS selected.

❑ **Preset activities for selected event**

Displays the list and order of execution of the actions set for the selected event.

❑ **"Move up" and "Move down" Buttons**

These are used to increase or decrease the priority of execution of the selected action.

❑ **"Add", "Edit" Buttons**

These two buttons allow you to define a new action (or to alter its parameters) relating to the current event.

The actions that can currently be implemented are as follows:

- ✓ *Pop-up message:* (#) displays a message on the monitor of a specified user (key in * to include all users in the domain / work group) describing the type of event that took place.
- ✓ *Write in LOG file:* stores the type of event that took place in the LOG file.
- ✓ *Execute local shutdown:* executes the shutdown of the computer interfaced with the UPS.
- ✓ *Remote SHUTDOWN command:* (##) executes the shutdown of a remote computer in the network.
- ✓ *Remote MESSAGE command:* (##) sends a message to a remote computer in the network.
- ✓ *Remote CUSTOM command [1, 2, 3]:* (##) executes custom commands on a computer in the network.
- ✓ *Execute local programme:* executes any executable file on the disk.
- ✓ *Send e-mail:* (###) sends an internal or external e-mail to the specified address.

(#) The sending of this type of message must be supported by the operating system and depends on the type of installation for the UPS server (see section "System – Install as system service").

(##) Requires installation and correct configuration of RS System on remote computers.

(###) Requires a valid account with a SMTP server.

❑ **"Default" Button**

Loads the default configuration for the combination of events/actions eliminating any modification made by the user.

❑ **"Load", "Save" Buttons**

Loads or saves a customised series of combinations of events/actions. This function is particularly useful in circumstances of multiple installations which are all identical, as you simply need to define a customised series of actions, save them on disk, copy them and load them onto the other installations without the need to repeat the configuration for this section each time.

2.3. RS System Configuration

The RS System configuration programme runs automatically at the end of installation or by clicking the appropriate icon. To ensure RS System will function correctly, you must complete the initial configuration so that the programme is able to install the RS server as system service (the type of "service" depends on the operating system in use).

2.3.1. "IP Address" Section

This section is used for the configuration of the IP addresses of the computers enabled to send commands to the RS server.

- ❑ **Computers authorised to send commands to the RS server**
Displays the list of the enabled IP addresses.
- ❑ **"Add", "Edit", "Delete" buttons**
These are used, respectively, to add, modify or delete an IP address.
- ❑ **"Move up" and "Move down" buttons**
These are used to move an IP address up or down with respect to another.
- ❑ **"Advanced..." button**
Provides access to Advanced Configuration of RS System.
- ❑ **TCP/IP listen port**
This is the IP port that the UPS server uses to communicate with the RS server.

2.3.2. "Scripts" Section

The Scripts section is used to specify the programmes that must be run when one of the valid commands is received.

- ❑ **Shutdown Script**
This specifies the file to execute should the shutdown command be received.
- ❑ **Customised Script [#1, #2, #3]**
This specifies the file to execute should CUSTOM 1, 2 or 3 commands be received. This command enables execution of any file that it is possible to execute (*.com; *.exe; *.bat; *.cmd) and can be used for any function whatsoever. We advise the association of a batch file (*.bat; *.cmd) to CUSTOM events in order to avoid problems in the transfer of parameters to the file to be executed and to simplify subsequent modifications to the command itself without having to restart the RS server each time.

2.3.3. "LOG File" Section

This section determines the writing of the LOG file by the RS server. The LOG file makes it possible to keep a trace of all the server's activities, including reception of invalid commands or commands sent by unauthorised computers.

- ❑ **Enable writing of LOG file**
Enables or disables the writing of the LOG file.

❑ **Maximum file size**

This specifies the maximum size of the LOG file, in bytes. Once this has been reached, the file is deleted and a new one is created.

2.3.4. Advanced Configuration

In normal situations, the UPS server sends commands to RS System, which then executes them (a typical application is the execution of the shutdown of remote computers). It could come to pass, however, that the UPS server shuts down (for example, due to the computer, where it is installed, being switched off in an irregular manner): in this case, the power cut could drain the UPS batteries causing it to shut down, subsequently switching off the power to any load, and thus invalidating the protection offered by RS System.

This section makes it possible to verify the presence of one or more UPS servers at regular intervals and to execute a customised command should it fail to locate one or more UPS servers.

N.B: the command is also executed even if only one of the UPS servers, contained in the list of those enabled, fails to be located (see the “IP Address” – Computers authorised to send commands to the RS server Section).

❑ **Enable regular search**

Enables, or disables, the UPS server search

❑ **Search frequency [m]**

This represents the frequency, shown in minutes, for the execution of the UPS server search.

❑ **Attempts**

Should the UPS server search fail, this specifies how many attempts will be made before ascertaining that a particular UPS server cannot be located.

❑ **TCP/IP Port**

The TCP/IP port used for the execution of the UPS server search.

❑ **Interval between attempts [s]**

The interval, shown in seconds, between one search and the next in case a UPS server is not found (see *Retries*).

❑ **“Verify connections” button**

This is used to check the connections with the UPS servers. The result is displayed in a table, which provides the outcome and the number of attempts made, in addition to the IP addresses of the UPS servers.

As this is a test, no consequential action will be taken, even if the outcome is negative.

❑ **Execute in case of search failure**

This specifies which command should be executed in case of search failure. It is possible to specify any type of file than it is possible to run (*.com, *.exe, *.bat, *.cmd). We advise the association of a batch file (*.bat; *.cmd) to CUSTOM events in order to avoid problems in the transfer of parameters to the file to be executed and to simplify subsequent modifications to the command itself without having to restart the RS server each time.

2.4. UPS Diag Monitor utilisation

The following paragraphs refer to the full set of functions supported by *UPS Diag*; not all models of UPS support these functions. Therefore, it may occur with your UPS that certain information is not visible.

2.4.1. Connecting and disconnecting to a UPS Server

In order to allow *UPS Diag* to interact with a UPS, you must connect up to a UPS server residing within the same computer or on a remote LAN or WAN computer (it is important that a network connection is established and that the TCP/IP protocol is present).

A connection screen containing the options shown below is displayed by means of the “File|Connect ...” menu, the relative button on the Toolbar or by clicking the right mouse button and selecting “Connect...”:

- Local Host**
Local connection (same computer for *UPS Diag* and for the UPS server).
- Remote Host**
Remote connection (different computers for *UPS Diag* and for the UPS server).
- IP address or Host Name**
Only available if *Remote Host* has been selected. Requires the name or IP address of the computer that you want to connect up to.
- Find**
Only available if *Remote Host* has been selected. Displays Windows “Network Resources” to facilitate the search for the computer where the UPS server is located.
- Advanced**
This is used for modifying the TCP/IP communications port between *UPS Diag* and UPS server. Modification of this setting also requires modification of the port used by the UPS server (see UPS Server configuration).

Press OK to confirm the data and run the procedures for connecting *UPS Diag* to the UPS server: if the settings have all been completed correctly, the main UPS data will appear with a message confirming successful connection with the UPS server.

However, if the “*File|Disconnect*” menu or the relative button on the ToolBar is used, or the right mouse button is clicked and “Disconnect” is selected, the current connection will be terminated.

It is possible to run *UPS Diag Monitor* specifying certain parameters on the command line so that the connection will automatically be started with a UPS server:

- C**<computer name> Name or TCP/IP address of the computer where connection is desired
- P**<tcp/ip port> TCP/IP port used by the UPS server for the exchange of information. If this parameter is not specified, the default port 5769 is used.

E.g.:

To connect up to the computer whose address is 192.168.0.1 and to port 5000, enter:

```
<installation_path>\bin\UpsDiag.exe C191.168.0.1 P5000
```

Note: there must be no spaces between the parameter and the data.

2.4.2. Monitoring the UPS

2.4.2.1. Information Panel

The information panel displays the main information regarding the UPS being monitored.

- ❑ **UPS Model**
Name of the UPS.
- ❑ **Family**
Identifies the product family.
- ❑ **Nominal Power [VA]**
Nominal power according to current European standards, shown in Volt-Amperes.
- ❑ **Nominal Power [W]**
Nominal power according to current European standards, shown in Watts.
- ❑ **Number of Modules Installed**
Number of power boards fitted inside the UPS.
- ❑ **Firmware version**
Number of the release of the microprocessor's internal firmware.
- ❑ **Serial Number**
The serial number.

The panel also displays whether you need to carry out a test in order to calibrate the effective autonomy of the UPS based on the load connected (See *Autonomy Calibration Test*).

2.4.2.2. View Log file

The display of the Log file is represented by a list of items, integrated with date and time, concerning events occurring outside the UPS recorded by the UPS server during its operation. This can be saved, printed or sent by e-mail.

2.4.2.3. View Data file

The display of the Data file is represented by a list of the UPS operating specifications, which can be selected by means of the UPS server's configuration programme and integrated with date and time, recorded by the UPS server during its operation. This can be saved, printed or sent by e-mail.

A chart can be generated from this file to represent the trend of these measurements over time. This is why the CSV extension is proposed when saving the file, to allow rapid analysis with Microsoft Excel.

2.4.2.4. Operating data

Displays the main, real time specifications of the UPS.

- ❑ **UPS status**
Identifies the current operating status of the UPS. The possible statuses are:
 - Mains UPS operating on mains power
 - Battery UPS operating on battery power
 - Reserve UPS operating on battery power but has low batteries
 - Bypass UPS is in bypass mode for one of the following reasons:
 - forced bypass
 - off-line operation
 - overload
 - internal anomaly

- ❑ **Autonomy**
Estimated useable autonomy for the UPS before execution of computer shutdown.

- ❑ **Anomaly**
Description of a UPS operating anomaly, if any. The possible descriptions are:
 - None Everything is OK
 - Overload Load is too high for the UPS
 - Overheating Temperature of one of the internal boards is above the threshold limit
 - Internal anomaly Probable UPS fault
 - Battery charger One of internal battery chargers is faulty
 - Battery fault Batteries must be replaced

- ❑ **Current load**
Percentage of connected load.

- ❑ **Temperature**
Temperature inside the UPS.

- ❑ **Battery charge**
Estimated percentage of battery charge.

2.4.2.5. Input Data

Displays all the specifications in real time regarding the mains electricity supply to the UPS.

- ❑ **Input voltage**
RMS voltage, shown in Volts, of the input line.

- ❑ **Apparent input power**
Apparent power, shown in Volt-Amperes, absorbed by the input line.

- ❑ **Active input power**
Active power, shown in Watts, absorbed by the input line.

- ❑ **Input current**
RMS current, shown in Amperes, absorbed by the input line.

- ❑ **Input peak current**
Peak current, shown in Amperes, absorbed by the input line (not to be confused with peaks of absorption).

- ❑ **Stabiliser level**
Displays the stabiliser's centring value when the UPS is running on mains power.

- ❑ **Neutral Sensor enabled**
The neutral sensor is able to inhibit the operation of the UPS in circumstances where the neutral potential shifts excessively from that of earth. During installation, it is useful for verifying that the power supply plug has been inserted correctly into the power outlet and will prevent its operation in case of error. To start the UPS, simply invert the plug and switch it back on. The function is inhibited if this option is disabled.
- ❑ **Neutral Sensor while running**
This shows whether the UPS must ignore any excessive shift of the neutral potential away from earth and only provide an acoustic warning signal (the UPS would normally switch over to battery power until fully discharged and then switch off).
- ❑ **PLL enabled**
Normally, the UPS will tolerate fluctuations in input frequency within certain limits. If this parameter is disabled, the UPS will accept any input frequency but still supply the nominal output frequency of 50 Hz (or 60 Hz).
- ❑ **Extended PLL range**
This specifies whether the UPS must extend the range of mains frequencies accepted (refer to the UPS instructions manual for further details).

2.4.2.6. Output Data

Displays all the UPS output specifications in real time:

- ❑ **Output voltage**
RMS voltage, shown in Volts, supplied by the UPS.
- ❑ **Apparent output power**
Apparent power, shown in Volt-Amperes, absorbed by the load connected.
- ❑ **Active output power**
Active RMS power, shown in Watts, absorbed by the load connected.
- ❑ **Output current**
RMS current, shown in Amperes, absorbed by the load connected.
- ❑ **Output peak current**
Maximum repetitive peak current, shown in Amperes, absorbed by the load (not to be confused with peaks of absorption).
- ❑ **Output voltage frequency**
The frequency, shown in Hertz, of the output voltage.
- ❑ **Bypass enabled**
This shows the status of the UPS management of the automatic bypass.
If this option is disabled, the bypass will never enter operation.
- ❑ **Forced bypass**
This specifies whether the user has intentionally put the UPS into bypass.
This function should only be used in special circumstances as the UPS and the load connected would switch off immediately if there were a power failure.
- ❑ **Speed of bypass intervention**
Displays the setting for the intervention speed of the automatic bypass when required.
- ❑ **Off-line mode**
This specifies whether the UPS is operating as a normal on-line UPS (with option disabled) or as a non-stabilised switchover UPS (with option enabled).

- ❑ **Load waiting mode**
Displays the status of the automatic switching on/off function of the UPS, which operates according to the switching on and switching off of its connected load.
- ❑ **Threshold for load recognition**
Displays the power threshold, shown in Watts: the UPS will go into stand-by below this (if the *Load Waiting Mode* function has been enabled) due to the connected load being switched off.

2.4.2.7. Batteries

Displays the voltage of the batteries in real time and the relative operating thresholds.

- ❑ **Current value**
Current battery voltage, shown in Volts.
- ❑ **Threshold for autonomy reserve**
The threshold, shown in Volts: the UPS will indicate that the batteries are low below this.
- ❑ **Threshold for end of autonomy**
The threshold, shown in Volts: the UPS will switch off because of fully discharged batteries below this.
- ❑ **Battery thresholds mode**
The two thresholds relating to the batteries (autonomy reserve and end of autonomy) are the collating data used by the UPS to establish the status of the charge of the batteries.
These thresholds can be managed automatically by the UPS by way of its *Automatic* setting (when the connected load varies, these thresholds will also vary) or can be given permanent voltage settings by the user by way of its *Fixed* setting.
- ❑ **Automatic battery test at UPS switch on**
This specifies whether the UPS must execute a battery test each time it is switched on provided mains power is present.
- ❑ **Max operating time in battery mode**
If specified, this indicates the maximum time the UPS will be able to operate after a mains power failure. At the end of the set time, the UPS will automatically switch off unless the mains power supply has been restored.
- ❑ **Max operating time after autonomy reserve**
If specified, this indicates the maximum time the UPS will be able to operate after the autonomy reserve signal has been given. At the end of the set time, the UPS will switch off immediately even if the mains power supply has been restored in the meantime.
- ❑ **Autorestart after end of autonomy**
Shows whether the UPS has been enabled to switch back on automatically, after switching off due to a power failure, when the mains power supply has been restored.

2.4.2.8. Hardware Information

Displays all the information relating to the UPS hardware in real time: this can be useful for diagnosing faults.

- ❑ **Number of failed modules**
Identifies the number of UPS power boards, which have currently failed.
- ❑ **Description of failed module**
Identifies the type of failure of one or more UPS power boards. The following descriptions are possible (including combinations of the same):
 - **Unknown** Failure unknown
 - **Inverter** Inverter
 - **P.F.C.** Input voltage rectifier and booster
 - **Booster** Battery voltage booster
 - **Overheat** One power board or more has overheated
 - **Battery charger** Battery charger
- ❑ **A/D Vin, Iin, Vout and Iout converter**
Internal UPS data for exclusive use of the Service Centre.
- ❑ **Positive and Negative BUS voltage**
Internal UPS data for exclusive use of the Service Centre.

2.4.2.9. Input and Output Sine Waves

Chart format representation of the performance of the UPS input (or output) voltage and current in real time.

2.4.2.10. UPS History

List of the cumulative operating data for the UPS. This data is continually updated and permanently stored in the UPS.

- ❑ **Total UPS operating time**
Represents the total time of UPS operation.
- ❑ **Total operating time in battery mode**
Represents the total time the UPS has been operating on battery power.
- ❑ **Number of battery interventions**
Represents the number of times the UPS batteries have intervened.
- ❑ **Complete battery discharges**
Represents the number of times the UPS has switched off due to fully discharged batteries (caused by lengthy power failures) or due to the setting chosen for the *Max operating times*.
- ❑ **Number of bypass interventions**
Represents the total number of times the Bypass has intervened.
- ❑ **Overheatings**
Represents the number of times that the temperature of one or more power boards has exceeded the set limit.
- ❑ **Number of stabiliser interventions**
Represents the total number of times the stabiliser has intervened.

2.4.2.11. List of Events

The list of events occurring during the operation of the UPS is continually updated and is stored permanently in the UPS memory. Some UPS models also memorise the date and time in addition to the type of event.

The list of possible events is as follows:

- ❑ **None**
No anomaly.
- ❑ **Odd Turn Off**
UPS shutdown due to disconnection of the battery supply (during operation in battery mode or switching on).
- ❑ **Memory Error!**
Error in the UPS internal memory. **Contact your Service Centre.**
- ❑ **Battery Limit**
UPS shutdown due to complete batteries discharge caused by a prolonged absence of mains or attempt to switch on the UPS in battery mode after a shutdown due to complete battery discharge.
- ❑ **Battery Charger**
Failure of the battery charger of one or more power boards.
- ❑ **Overload**
UPS shutdown due to overload during battery operation.
- ❑ **Long Overload**
Overload longer than 5 seconds while the UPS was operating in mains mode. The UPS switches to bypass mode and remains on bypass until the load returns within nominal range.
- ❑ **Neutral Wrong**
Error in input neutral connection during start up. After about 10 seconds the UPS switches off.
- ❑ **Neutral Wrong While Running**
Error in input neutral connection during operation. The UPS switches over to battery or it remains connected to the mains.
- ❑ **Modules Number**
Microprocessor is not able to define how many power modules are installed inside the UPS. **Contact your Service Centre.**
- ❑ **Programmed Battery Time Expired**
UPS shutdown at the end of the programmed *"Max. operating time in battery mode"*.
- ❑ **Programmed Reserve Time Expired**
UPS shutdown at the end of the programmed *"Max. operating time after autonomy reserve"*.
- ❑ **Earth Fault**
UPS shutdown due to the intervention of its internal electronic output differential device, which revealed a current leakage towards the earth.
- ❑ **Load Waiting**
UPS shutdown due to a power failure while the UPS was in load waiting mode.
- ❑ **HV Bus Runaway**
UPS shutdown due to a loss of control of the internal BUS high voltage. **Contact your Service Centre.**
- ❑ **Output DC Level**
UPS shutdown due to the failure of one internal inverter. **Contact your Service Centre.**

- ❑ **Bad Wiring**
Error in UPS connection. Basically an attempt was made to feed the UPS through the output socket.
- ❑ **Output Plug Removed**
UPS shutdown due to the disconnection of input/output connector.
- ❑ **Hardware Fault:**
Failure of one or more of the electronic circuits on one or more of the power boards.
The possible faults (including combinations of the same) are listed below; in any event, **contact your Service Centre:**
 - **Unknown** Failure unknown
 - **Inverter** Inverter
 - **P.F.C.** Input voltage rectifier and booster
 - **Booster** Battery voltage booster
 - **Overheat** One power board or more has overheated
 - **Battery charger** Battery charger

The list of these events can be saved, printed or sent by e-mail.

2.4.3. Scheduling

Scheduling options can be accessed through the Tools|Scheduling menu and are the best way to optimise the use of the UPS and the load it is powering.

There are three scheduling categories:

- Switch off /Restart: The switching off and subsequent (or not) restarting of the UPS
- Battery test: Battery test
- Autonomy calibration test: Test for the calibration of UPS autonomy

The frequency of execution of each of the categories described above can be selected from the following:

- One shot: executed once only on a set date and time
- Daily: executed every day at a set time
- Weekly: executed every week on a set day and at a set time

After selecting the options required, click on “Add” to add the new schedule to the list of current schedules.

To delete an individual schedule, use the right mouse button to select it from the list and then click on “Remove” in the popup menu that will appear (*One shot* schedules are automatically eliminated after they have been executed or when the set day and time has passed if execution not possible).

It is not possible to alter schedules: they must be deleted and a new one created.

It is possible to delete all the schedules in a single category by selecting the category itself from the list using the right mouse button and then clicking on “Remove” in the popup menu that will appear.

You must press “Save” for the modifications to take effect and be transferred to the UPS server, which will then manage them independently.

You can check the result of the execution of each individual scheduling by controlling the UPS server’s log file (if enabled).

N.B: UPS Switch off/Restart must be enabled for scheduling to work correctly (see “*UPS Server Configuration –Shutdown section*”).

2.4.4. Send a shutdown command to <computer_name>

This enables execution of the shutdown of the computer connected to the UPS, provided this has been enabled in the configuration of the UPS server.

2.4.5. Setting the UPS parameters and functions

2.4.5.1. UPS Setup

UPS set-up is the system used to alter its operating parameters and enable certain special functions. If a password has been specified during the configuration of the UPS server, it must be entered in order to access this type of functions.

The set-up window is divided into categories so that options are grouped together in a logical fashion. You must click on “Save” for any modification to take effect.

2.4.5.1.1. Input

Settings for the operating parameters relating to the UPS input.

- Stabiliser Level**
This is used to modify the stabiliser’s centring value when the UPS is running on mains power.
- Enable neutral sensor**
The neutral sensor is able to inhibit the operation of the UPS in circumstances where the neutral potential shifts excessively from that of earth. During installation, it is useful for verifying that the power supply plug has been inserted correctly into the power outlet and will block operation in case of error. To start the UPS, simply invert the plug and switch it back on. This function will be inhibited if this option has been disabled.
- Ignore neutral sensor while running**
If this function is enabled, the UPS is allowed to ignore any excessive shift of the neutral potential away from earth and will only provide an acoustic warning signal (the UPS would normally switch over to battery power until fully discharged and then switch off).
- Enable PLL**
Normally, the UPS will tolerate fluctuations in input frequency within certain limits. If this parameter is disabled, the UPS will accept any input frequency but still supply the nominal output frequency of 50 Hz (or 60 Hz).
- Extended PLL range**
This specifies whether the UPS must extend the range of mains frequencies accepted (refer to the UPS instructions manual for further details). This function is only operational if the “*Enable PLL*” function has been enabled).

2.4.5.1.2. Output

Settings for the operating parameters relating to the UPS output.

- ❑ **Output voltage**
This is used to set the output voltage for the UPS (within a pre-determined range).
- ❑ **Output voltage frequency**
This parameter can be used to set the output frequency of the UPS to either 50 Hz or 60 Hz. If the *Enable PLL* parameter is set, the input will also be synchronised to accept the same frequency.
- ❑ **Automatic recognition of input frequency**
This is used to automatically set the input/output frequency of the UPS according to the power supply line.
- ❑ **Enable bypass**
This option is used to enable automatic UPS management of the bypass.
Disabled bypass mode should only be used under special circumstances as the bypass will never enter operation with the possibility of UPS shutdown should there be an overload or internal failure.
- ❑ **Forced bypass**
This is used to switch the bypass on permanently or to leave its management to the UPS (if the “*Enable bypass*” function has been enabled).
This function should only be used in special circumstances as the UPS and the load connected will immediately switch off if there is a power failure.
- ❑ **Speed of bypass intervention**
This option is used to set the speed for the intervention of the automatic bypass.
- ❑ **Off-line operating mode**
This is used to select the UPS operating mode (only available for on-line UPS):
 - Disabled: the UPS operates like a normal on-line UPS
 - Enabled: the UPS goes into bypass and behaves like a non-stabilised switchover UPS, with mains efficiency of around 99%
- ❑ **Load waiting mode**
This is used to enable or disable the automatic switching on/off function of the UPS so that it operates according to the switching on and switching off of the connected load.
- ❑ **Threshold for load recognition**
This is to set the power threshold so that the UPS will go into stand-by below this limit (if the *Load Waiting Mode* function has been enabled) due to the connected load being switched off.

2.4.5.1.3. Batteries

Used for setting the operating parameters relating to the batteries inside the UPS.

- ❑ **Max. operating time in battery mode**
If this function is enabled, it allows a maximum time to be specified (in minutes and seconds) for the UPS to run on battery power. At the end of the set time, the UPS will automatically switch off unless the mains power supply has been restored. If the “*Autorestart after the end of autonomy*” option has been enabled, the UPS will automatically switch back on when mains power is restored.
- ❑ **Max. operating time after autonomy reserve**
If this function is enabled, it allows a maximum time to be specified (in minutes and seconds) for the UPS to run in its autonomy reserve. At the end of this time, the UPS will switch off even if the mains power supply has been restored in the meantime. If the “*Autorestart after the end of autonomy*” option has been enabled, the UPS will automatically switch back on when mains power is restored.

❑ **Autorestart after end of autonomy**

If this function is enabled, the UPS can be set so it will automatically switch back on when the mains power supply has been restored if it switched off because of the complete discharging of its batteries or due to the settings for “*maximum operating times*”.

❑ **Battery thresholds**

The two thresholds relating to the batteries (autonomy reserve and end of autonomy) are the collating data used by the UPS to establish the status of the charge of the batteries.

These thresholds can be managed automatically by the UPS by way of its *Automatic* setting (when the connected load varies, these thresholds will also vary) or can be given permanent voltage settings by the user by way of the *Fixed* setting.

If ‘fixed’ settings are preferred, both thresholds can be set within predetermined limits:

- Autonomy reserve: below this threshold, the UPS will indicate that the batteries are low (Low Battery).
- End of autonomy: below this threshold, the UPS will switch off due to fully discharged batteries.

❑ **Automatically execute a battery test when UPS is switched on:**

This enables the execution of a battery test each time the UPS is switched on, provided mains power is present (does not apply after switching off due to end of autonomy).

2.4.5.1.4. Clock

This is used to set the date and the time of the clock inside the UPS.

2.4.5.1.5. Programming

For setting the operating parameters relating to the actual UPS programming (not to be confused with UPS server scheduling).

These programming options are independently executed by the UPS and do not affect any external software for control and/or shutdown. They should, therefore, be used with extreme caution as they could result in unwelcome effects when power is being supplied to computers.

❑ **Enable programming**

Enables or disables the execution of internal UPS programming options.

❑ **Programming table**

This table grants access to the actual settings of the individual programming options.

It is possible to programme the following actions:

- UPS switch off: UPS switching off (without shutdown of the computer)
- UPS restart: UPS switching on
- Battery test: Execution of a test of the batteries
- Calibration Test: Execution of a test of the calibration of the batteries (the UPS server does not take this result into consideration)

A type can be specified for each action (i.e. the frequency of execution) and a series of values (parameters):

- One shot: Date and time of execution
- Daily: Time of execution
- Weekly: Day of the week and time of execution
- Monthly: Day of the month and time of execution

Refer to the UPS manual for further information regarding programming.

2.4.5.2. Enable Buzzer

This is used to silence (not permanently) or reactivate the acoustic warning signals provided by the UPS.

2.4.5.3. Battery test

This executes a test to verify the efficiency of the batteries inside the UPS. The type of response depends on the model of UPS connected.

2.4.5.4. Autonomy Calibration Test

This test is used to synchronise the data relating to the actual autonomy and battery capacity of the UPS with the UPS server.

In effect, when the software is installed for the first time, the UPS server is not capable of recognising the actual autonomy of the UPS and therefore uses the default setting of 5 minutes.

Executing this test (which should be repeated at least once every year) ensures this data is synchronised and updated to safeguard optimum operation of the UPS server.

If the load varies $\pm 10\%$ compared to the percentage of load applied at the time of the last test, the UPS Diag information panel will inform the user that the test should now be repeated.

Test procedure:

- The UPS switches over to battery power (the user is not informed of this) and starts its internal counter
- The UPS waits for the autonomy reserve signal
- The UPS restores normal operation
- The time this took is memorised along with the percentage of load

Notes on the procedure:

- The test must be executed with all the applied load switched on
- If the test is interrupted by the user, the new data for the autonomy will be the time taken until that moment
- At the end of the test, the batteries in the UPS will be discharged therefore the readings for “autonomy” and “battery capacity” will be zero.
- The UPS and the computer where the UPS server is installed must be left on until the batteries are fully recharged again.

2.4.5.5. Reset Battery History

This is used to delete the history of the batteries, i.e.:

- Total operating time in battery mode
- Number of battery interventions
- Complete battery discharges

This function should only be used after the batteries have been replaced or after contacting the Customer Service Centre because deletion of this information could jeopardize the rapid diagnosis of UPS problems.

2.4.5.6. Reset Events List

This is used to delete the list of events stored in the UPS memory.

This function should only be used after maintenance by an authorised service technician or after contacting the Customer Service Centre because deletion of this information could jeopardize the rapid diagnosis of UPS problems.

2.5. System Shutdown

The programme Winshut.exe, contained in “<installation_path>\bin\”, is used by the UPS server and by RS System to execute the shutdown of the operating system.

The syntax of the command is as follows:

Winshut.exe [/F] [/O] [/R] [/T:xx]

- /F** Forces the execution of shutdown (automatically closes all open or blocked programmes) without saving data.
If this option is not used, programmes that are open may request data to be saved, or blocked programmes may not close, this cancelling the shutdown.
- /O** Switches off the computer at the end of shutdown (the operating system and the hardware must support this function otherwise the operating system will restart the computer instead of shutting down).
- /R** Executes reboot. This option takes priority over previously mentioned options and thus it has to be used very carefully.
- /T:xx** Displays a warning message on the monitor with the countdown (in seconds and shown as xx): shutdown of the computer will start at the end of this.
Use this parameter with caution as in effect it delays the start of shutdown.

2.5.1. UPS Server Script

The *LclDown.bat* shutdown script, contained in the “<installation path>\Script\System” folder makes it possible to specify the programme to be executed in order to obtain a local system shutdown. The original contents of the file is as follows:

```
@ECHO OFF
"<installation_path>\bin\WinShut.exe" /F
REM -- End of file --
```

N.B: shutdown is a process that should be completed as rapidly as possible, therefore we advise against the inclusion of programmes in this script. Refer to “*UPS server Configuration – Events section*” for information relating to customisation of shutdown.

2.5.2. RS System Script

The original contents of this script (*RsDown.bat*, contained in the < installation path >\Script\System folder) is as follows:

```
@ECHO OFF
"<installation_path>\bin\WinShut.exe" /F /T:10
REM -- End of file --
```

As can be seen above, the script contains a single line of command. i.e. the start of the shutdown programme.

N.B: shutdown is a process that should be completed as rapidly as possible, therefore we advise against the inclusion of programmes in this script.

2.6. Utility programmes

2.6.1. UPS Binder

UPS Binder is the “control panel” for the entire UPS Communicator package: it enables all the individual modules in the software to be managed from a single interface (certain limitations are possible with the NT platform).

2.6.2. LOG file viewer

The *Log Viewer* programme is a simple viewer used for the local display, searching and printing of the various LOG files without necessarily switching on the *UPS Diag* monitoring client.

3. Linux

3.1. Installing UPS Communicator

The software is very simple to install and needs to be executed as a **root** user.

Procedure:

2. Unzip the zip file downloaded off the Internet into a temporary folder (two files are obtained: one is the installation package with the extension *.tar.gz*, whilst the other is a document containing the instructions for unzipping the installation package)
3. Read the *readme.txt* file for instructions on unzipping the *.tar.gz* file
4. Run the *setup* programme contained in the folder created when the *.tar.gz* file was unzipped
5. Select the language (used for messages to users and for the information regarding license and modules to be installed)
6. Confirm you accept the terms of the license
7. Key in the User Name, Organisation and Serial Number (sent by e-mail after registering via the website http://www.metasystem.it/ups/communicator/gb_index.htm)
8. Select the modules to be installed:
 - UPS Server (“Master” mode): Module for UPS communications and management. Selection of this module also implicates installation of the “UPS Diag Monitor” monitoring module
 - RS System (Remote Shell – “Slave” mode): Module for executing shutdown, messages and programmes of remote computers
9. Decide whether to complete the configuration of the modules installed immediately (recommended)
10. Decide whether to start up all the modules installed immediately (only reply yes if configuration of the modules has been completed)
11. Decide whether to automatically run the modules installed when the computer is started up (recommended)
12. Finished. The application has been installed in: `/usr/metasystem/upscomm/`

3.2. UPS Server Configuration

In order to work correctly, the UPS server requires certain parameters: this information can be set using the “upscfg” configuration programme located in “/usr/metasystem/upscomm/bin” and which can only be run by the **root** user.

The configuration parameters are divided into categories that can be selected from the main programme menu.

The parameters must be saved at the end of configuration by means of the appropriate option in the menu: should the UPS server already be running, a message is displayed notifying you that the UPS server must be switched off and restarted.

3.2.1. “System Configuration” menu

Accurate setting of these parameters is essential in order to safeguard correct communications with the UPS.

- ❑ **UPS Model**
This specifies the model of UPS interfaced with the computer.
Selecting the UPS model will restore the default settings for the autonomy data and any customised actions set in the “Events Configuration” section.
- ❑ **Battery recharge time**
This specifies the total time, in hours, required by the UPS in order to recharge the batteries after they have been completely discharged; it is set automatically when the UPS model is selected.
We recommend leaving the default setting for this parameter unless a more batteries have been fitted than standard or if additional battery chargers have been installed.
- ❑ **Location of UPS / Computer**
This specifies the actual location of the UPS or of the computer that it is interfaced with (for example: EDP room; office 2nd floor; etc...).
- ❑ **Device for communications**
This enables you to specify the computer’s serial port used for connection of the UPS:
/dev/ttyS0 = COM1
/dev/ttyS1 = COM2
.....
- ❑ **TCP/IP listen port**
This is the TCP/IP port used for communications by the UPS server and the UPS Diag Monitor clients. The parameter can be altered should this port already be used by another programme in the system; in this case, however, you must do the same on the monitoring client during the request for connection to the UPS server.
- ❑ **Password for UPS Monitor**
This specifies the password used by the monitoring client in order to access certain special functions, such as UPS set-up, tests and programming of switching off and switching back on. The password is optional.
- ❑ **Broadcast event interval**
This is the frequency, in seconds, of the actions set for the option “Broadcast event - UPS still in battery mode” to be carried out by the UPS server (these are normally messages to users notifying them of the time that remains before shutdown will start). The event will only be managed if the UPS is operating on battery power, further to an actual mains power failure, and if the “Enable System Shutdown” option has been enabled.

3.2.2. “Shutdown Configuration” menu

The parameters of this section are needed for the management of UPS autonomy, system shutdown, the switching off and subsequent automatic restarting of the UPS.

❑ **Enable System Shutdown**

Enables or disables the possibility for the UPS server to execute automatic system shutdown.

If the application is used exclusively for UPS diagnostics, we recommend this setting be disabled.

❑ **Autonomy management type**

This gives you the possibility to manage the autonomy (provided this is permitted by the currently selected UPS) with two different and, in a certain way, opposite methods:

- ✓ *Advanced:* the UPS server uses all the autonomy of the UPS except for the autonomy reserve and the time specified in the parameter *Time needed for system shutdown*.
- ✓ *Fixed:* shutdown always starts x minutes after the UPS has switched over to battery power.

N.B: shutdown always starts immediately when the autonomy reserve signal has been reached (batteries flat).

❑ **Time needed for system shutdown**

Only visible if “advanced” management of autonomy has been specified. It indicates how long (in minutes) the computer needs to complete its shutdown procedure. If the parameter *Enable UPS shutdown* has been selected, we recommend setting the actual time needed for shutting down the computer plus one extra minute.

❑ **Execute shutdown after [m] in battery**

Only visible if “fixed” management of autonomy has been specified. It indicates how long, in minutes, shutdown of the computer will start after the UPS has switched over to battery power.

❑ **Allow shutdown from the UPS Monitor**

This specifies if it is possible to send the computer shutdown command from UPS Diag Monitor.

❑ **Enable UPS shutdown**

This gives you the possibility to enable or disable the automatic switching off of the UPS at the end of computer shutdown. If switch on/switch off scheduling is used (see *UPS Diag Monitor*), this parameter must be enabled.

❑ **Delay from start of system shutdown**

This gives you the possibility to specify after how many minutes the UPS should switch off, starting from the launch of the computer shutdown procedure. If “advanced” management of autonomy has been selected, the minimum amount that can be set is limited so that it is not possible to specify an amount of time below the setting for *Time needed for system shutdown* in order to prevent the UPS switching off when the computer shutdown procedure is still running.

❑ **Enable UPS restart**

Enables or disables the automatic switching on of the UPS after mains power has returned.

If switch on/switch off scheduling is used (see *UPS Diag Monitor*), this parameter must be enabled.

❑ **Delay from return of power**

This specifies how many seconds must pass after mains power has returned before the UPS automatically switches after being switched off because of a mains power failure.

3.2.3. "Log & Data" menu

The parameters contained in this section refer to the recording of data by the UPS server.

- ❑ **Enable recording of LOG file**
Enables or disables the writing on disk of UPS and external events.
- ❑ **Maximum file size**
This gives you the possibility to specify the maximum size in bytes for the events file. Once this has been reached, the file is deleted and a new one is created.
- ❑ **Enable recording of DATA file**
Enables or disables the writing on disk of the UPS and mains electricity operating specifications.
- ❑ **Maximum file size**
This gives you the possibility to specify the maximum size in bytes of the operating specifications file. Once this has been reached, the file is deleted and a new one is created.
- ❑ **Recording frequency rate**
This specifies the frequency, in seconds, of the writing of the operating specifications file.
- ❑ **Select data to be recorded**
This gives you the possibility to select the specifications from a list (input voltage, output voltage, etc...) to be stored in the file.

3.2.4. "Mail Server" menu

This section allows you to adjust the configuration of the programme's options for the sending of e-mails.

- ❑ **Sender's e-mail address**
This specifies the sender's e-mail address and is used to login to the SMTP server (if authentication is not required).
- ❑ **IP address of SMTP server**
Name or IP address of the mail server (SMTP) used to send e-mails.
- ❑ **Use SMTP authentication**
Enable this parameter if the mail server (SMTP) requires authentication and specify a valid *login* and *password*.

3.2.5. “Events Configuration” menu

The parameters in this section control how the UPS server behaves based on UPS or external events. All the events already have default settings for a range of actions relating to the event in question.

- ❑ **Possible events for current UPS**

This specifies the events managed by the UPS currently selected. The contents of this list may vary depending on the type of UPS selected.
- ❑ **Configured jobs list for current event**

Displays the list and order of execution of the actions set for the selected event.
- ❑ **“Move job Up” and “Move job Down”**

These are used to increase or decrease the priority of execution of the selected action.
- ❑ **“Insert job” and “Edit job”**

Allow you to define a new action (or to alter its parameters) relating to the current event. The actions that can currently be implemented are as follows:

 - ✓ *Pop-up message:* displays a message on the users console describing the type of event that took place.
 - ✓ *Write in LOG file:* stores the type of event that took place in the LOG file.
 - ✓ *Execute local shutdown:* executes the shutdown of the computer interfaced with the UPS.
 - ✓ *Remote SHUTDOWN command:* executes the shutdown of a remote computer in the network.
 - ✓ *Remote MESSAGE command:* sends a message to a remote computer in the network.
 - ✓ *Remote CUSTOM command [1, 2, 3]:* executes custom commands on a computer in the network.
 - ✓ *Execute local programme:* executes any executable file on the disk.
 - ✓ *Send e-mail:* sends an internal or external e-mail to the specified address.
- ❑ **Delete job**

Deletes the option selected with relation to the current event.
- ❑ **Reset Events to default**

Loads the default configuration for the combination of events/actions eliminating any modification made by the user.
- ❑ **“Load Events from file” and “Save Events to file”**

Loads or saves a customised series of combinations of events/actions. This function is particularly useful in circumstances of multiple installations which are all identical, as you simply need to define a customised series of actions, save them on disk, copy them and load them onto the other installations without the need to repeat the configuration for this section each time.

3.3. RS System Configuration

In order to work correctly, the RS server requires certain parameters: this information can be set using the “rscfg” configuration programme located in “/usr/metasystem/upscomm/bin” and which can only be run by the **root** user.

The configuration parameters are divided into categories that can be selected from the main programme menu.

The parameters must be saved at the end of configuration by means of the appropriate option in the menu: should the RS server already be running, a message is displayed notifying you that the RS server must be switched off and restarted.

3.3.1. “Authorized IP List” menu

This section is used for the configuration of the IP addresses of the computers enabled to send commands to the RS server.

- ❑ **“Insert”, “Edit”, “Delete”**
These are used, respectively, to add, modify or delete an IP address.

3.3.2. “Set TCP/IP Listen Port” menu

- ❑ **TCP/IP Listen Port**
This is the IP port that the UPS server uses to communicate with the RS server.

3.3.3. “Scripts Files Overview” menu

The Scripts section is used for displaying which programmes must be run when one of the valid commands is received. To modify or enter customised commands, edit the relative script.

- ❑ **Shutdown Script**
This specifies the file to execute should the shutdown command be received.
- ❑ **Custom script [#1, #2, #3]**
This specifies the file to execute should CUSTOM 1, 2 or 3 commands be received. This command enables execution of any file that it is possible to execute and can be used for any function whatsoever.

3.3.4. “LOG File Configuration” menu

This section determines the writing of the LOG file by the RS server. The LOG file makes it possible to keep a trace of all the server’s activities, including reception of invalid commands or commands sent by unauthorised computers.

- ❑ **Enable LOG file**
Enables or disables the writing of the LOG file.
- ❑ **Max file size**
This specifies the maximum size of the LOG file, in bytes. Once this has been reached, the file is deleted and a new one is created.

3.3.5. “Advanced Configuration” menu

In normal situations, the UPS server sends commands to RS System, which then executes them (a typical application is the execution of the shutdown of remote computers). It could come to pass, however, that the UPS server shuts down (for example, due to the computer, where it is installed, being switched off in an irregular manner): in this case, the power cut could drain the UPS batteries causing it to shut down, subsequently switching off the power to any load, and thus invalidating the protection offered by RS System.

This section makes it possible to verify the presence of one or more UPS servers at regular intervals and to execute a customised command should it fail to locate one or more UPS servers.

N.B: the command is also executed even if only one of the UPS servers, contained in the list of those enabled, fails to be located (see the “Authorized IP List” menu).

- ❑ **Enable regular search**
Enables, or disables, the UPS server search
- ❑ **Search frequency [m]**
This represents the frequency, shown in minutes, for the execution of the UPS server search.
- ❑ **Attempts**
Should the UPS server search fail, this specifies how many attempts will be made before ascertaining that a particular UPS server cannot be located.
- ❑ **TCP/IP Port**
The TCP/IP port used for the execution of the UPS server search.
- ❑ **Delay between attempts [s]**
The interval, shown in seconds, between one search and the next in case a UPS server is not found (see *Attempts*).
- ❑ **Execute when search fails**
This specifies which file should be executed in case of search failure.
Edit this file in order to insert commands you want to be executed.
- ❑ **Verify connections**
This is used to check the connections with the UPS servers. The result is displayed in a table, which provides the outcome and the number of attempts made, in addition to the IP addresses of the UPS servers.
As this is a test, no consequential action will be taken, even if the outcome is negative.

3.4. UPS Diag Monitor utilisation

UPS Diag Monitor can be started by running the “diagtext” programme located in “/usr/metasystem/upscomm/bin” and which can only be run by the **root** user.

The following paragraphs refer to the full set of functions supported by *UPS Diag Monitor*; not all models of UPS support these functions. Therefore, it may occur with your UPS that certain information is displayed as “not available”.

3.4.1. Connecting and disconnecting to a UPS server

In order to allow *UPS Diag Monitor* to interact with a UPS, you must connect up to a UPS server residing within the same computer or on a remote LAN or WAN computer (it is important that a network connection is established and that the TCP/IP protocol is present).

- Host IP address**
IP address of the computer to connect up to (leave empty for connection to local computer).
- Host IP Port**
Enables variation of the TCP/IP port for communications between UPS Diag and the UPS server (leave empty for use of default port).

If everything has been set correctly, the main menu will appear; otherwise an error message will be displayed.

3.4.2. Monitoring the UPS (“Read Data” menu)

Displays all the operating data for the UPS, divided according to category.

3.4.2.1. “UPS Info Read” menu

Displays the data relating to the type of UPS connected.

- Model Name**
Name of the UPS.
- Family Name**
Identifies the product family.
- Apparent Nominal Power**
Nominal power according to current European standards, shown in Volt-Amperes.
- Active Nominal Power**
Nominal power according to current European standards, shown in Watts.
- Number of Installed Modules**
Number of power boards fitted inside the UPS.
- Firmware Version**
Number of the release of the microprocessor’s internal firmware.
- Serial Number**
The serial number.

❑ **UPS/Computer Location**

The physical location of the UPS or the computer, as specified in the configuration of the UPS server.

3.4.2.2. "Main Data Read" menu

Displays the main specifications of the UPS.

❑ **UPS Status**

Identifies the current operating status of the UPS. The possible statuses are:

- Mains UPS operating on mains power
- Battery UPS operating on battery power
- Low Battery UPS operating on battery power but has low batteries
- Bypass UPS is in bypass mode for one of the following reasons:
 - forced bypass
 - off-line operation
 - overload
 - internal anomaly

❑ **Current Anomaly**

Description of a UPS operating anomaly, if any. The possible descriptions are:

- None Everything is OK
- Overload Load is too high for the UPS
- Overheat Temperature of one of the internal boards is above the threshold limit
- Hardware Fault Probable UPS fault
- Battery Charger One of internal battery chargers is faulty
- Battery fault Batteries must be replaced

❑ **Total Load**

Percentage of connected load.

❑ **Autonomy Time**

Estimated useable autonomy for the UPS before execution of computer shutdown.

❑ **Battery Capacity**

Estimated percentage of battery charge.

❑ **Internal Temperature**

Temperature inside the UPS.

❑ **Autonomy Calibration Test**

Status of the autonomy calibration test.

3.4.2.3. "Input Data Read" menu

Displays all the specifications regarding the mains electricity supply to the UPS.

❑ **Voltage**

RMS voltage, shown in Volts, of the input line.

❑ **Apparent Power**

Apparent power, shown in Volt-Amperes, absorbed by the input line.

❑ **Active Power**

Active power, shown in Watts, absorbed by the input line.

- ❑ **Current**
RMS current, shown in Amperes, absorbed by the input line.
- ❑ **Peak Current**
Peak current, shown in Amperes, absorbed by the input line (not to be confused with peaks of absorption).
- ❑ **Stabiliser Level**
Displays the stabiliser's centring value when the UPS is running on mains power.
- ❑ **Neutral Sense enabled**
The neutral sensor is able to inhibit the operation of the UPS in circumstances where the neutral potential shifts excessively from that of earth. During installation, it is useful for verifying that the power supply plug has been inserted correctly into the power outlet and will prevent its operation in case of error. To start the UPS, simply invert the plug and switch it back on. The function is inhibited if this option is disabled.
- ❑ **Neutral Sense while running**
This shows whether the UPS must ignore any excessive shift of the neutral potential away from earth and only provide an acoustic warning signal (the UPS would normally switch over to battery power until fully discharged and then switch off).
- ❑ **PLL enabled**
Normally, the UPS will tolerate fluctuations in input frequency within certain limits. If this parameter is disabled, the UPS will accept any input frequency but still supply the nominal output frequency of 50 Hz (or 60 Hz).
- ❑ **PLL extended lock range**
This specifies whether the UPS must extend the range of mains frequencies accepted (refer to the UPS instructions manual for further details).

3.4.2.4. "Output Data Read" menu

Displays all the UPS output specifications:

- ❑ **Voltage**
RMS voltage, shown in Volts, supplied by the UPS.
- ❑ **Apparent Power**
Apparent power, shown in Volt-Amperes, absorbed by the load connected.
- ❑ **Active Power**
Active RMS power, shown in Watts, absorbed by the load connected.
- ❑ **Current**
RMS current, shown in Amperes, absorbed by the load connected.
- ❑ **Peak Current**
Maximum repetitive peak current, shown in Amperes, absorbed by the load (not to be confused with peaks of absorption).
- ❑ **Frequency**
The frequency, shown in Hertz, of the output voltage.
- ❑ **Mains Frequency Autoselect**
Displays whether the UPS automatically selects the UPS input/output frequency depending on the frequency of the power line.

- ❑ **Bypass enabled**
This shows the status of the UPS management of the automatic bypass.
If this option is disabled, the bypass will never enter operation.
- ❑ **Forced Bypass enabled**
This specifies whether the user has intentionally put the UPS into bypass.
This function should only be used in special circumstances as the UPS and the load connected would switch off immediately if there were a power failure.
- ❑ **Bypass Dip Speed**
Displays the setting for the intervention speed of the automatic bypass when required.
- ❑ **Off Line Mode enabled**
This specifies whether the UPS is operating as a normal on-line UPS (with option disabled) or as a non-stabilised switchover UPS (with option enabled).
- ❑ **Load Waiting Mode**
Displays the status of the automatic switching on/off function of the UPS, which operates according to the switching on and switching off of its connected load.
- ❑ **Load Waiting Threshold**
Displays the power threshold, shown in Watts: the UPS will go into stand-by below this (if the *Load Waiting Mode* function has been enabled) due to the connected load being switched off.

3.4.2.5. "Battery Data Read" menu

Displays the voltage of the batteries and the relative operating thresholds.

- ❑ **Battery Voltage**
Current battery voltage, shown in Volts.
- ❑ **Reserve Threshold**
The threshold, shown in Volts: the UPS will indicate that the batteries are low below this.
- ❑ **Exhaust Threshold**
The threshold, shown in Volts: the UPS will switch off because of fully discharged batteries below this.
- ❑ **Thresholds Mode**
The two thresholds relating to the batteries ("Reserve Threshold" and "Exhaust Threshold") are the collating data used by the UPS to establish the status of the charge of the batteries.
These thresholds can be managed automatically by the UPS by way of its *Automatic* setting (when the connected load varies, these thresholds will also vary) or can be given permanent voltage settings by the user by way of its *Fixed* setting.
- ❑ **Auto Battery Test enabled**
This specifies whether the UPS must execute a battery test each time it is switched on provided mains power is present.
- ❑ **Max Time on Battery**
If specified, this indicates the maximum time the UPS will be able to operate after a mains power failure.
At the end of the set time, the UPS will automatically switch off unless the mains power supply has been restored.
- ❑ **Max Time after Reserve**
If specified, this indicates the maximum time the UPS will be able to operate after the autonomy reserve signal has been given. At the end of the set time, the UPS will switch off immediately even if the mains power supply has been restored in the meantime.

- ❑ **Autorestart enabled**
Shows whether the UPS has been enabled to switch back on automatically, after switching off due to a power failure, when the mains power supply has been restored.

3.4.2.6. "Hardware Data Read" menu

Displays all the information relating to the UPS hardware in real time: this can be useful for diagnosing faults.

- ❑ **Faulty Modules**
Identifies the number of UPS power boards that have currently failed.
- ❑ **Faulty type**
Identifies the type of failure of one or more UPS power boards. The following descriptions are possible (including combinations of the same):
 - **Unknown** Failure unknown
 - **Inverter** Inverter
 - **P.F.C.** Input voltage rectifier and booster
 - **Booster** Battery voltage booster
 - **Overheat** One power board or more has overheated
 - **Battery charger** Battery charger
- ❑ **Vin, Iin, Vout, Iout A/D Converter**
Internal UPS data for exclusive use of the Service Centre.
- ❑ **Positive, Negative BUS voltage**
Internal UPS data for exclusive use of the Service Centre.

3.4.2.7. "UPS History Read" menu

List of the cumulative operating data for the UPS. This data is continually updated and permanently stored in the UPS.

- ❑ **UPS operating time**
Represents the total time of UPS operation.
- ❑ **Inverter operating time**
Represents the total time the UPS has been operating on battery power.
- ❑ **UPS interventions**
Represents the number of times the UPS batteries have intervened.
- ❑ **Battery full discharges**
Represents the number of times the UPS has switched off due to fully discharged batteries (caused by lengthy power failures) or due to the setting chosen for the "*Max Time on Battery*" and "*Max Time after Reserve*" parameters.
- ❑ **Bypass/Stabiliser interv.**
Represents the total number of interventions of the Bypass or the stabiliser (depending on the type of UPS).
- ❑ **Overheatings**
Represents the number of times that the temperature of one or more power boards has exceeded the set limit.

3.4.2.8. "Event List Read" menu

The list of events occurring during the operation of the UPS is continually updated and is stored permanently in the UPS memory. Some UPS models also memorise the date and time in addition to the type of event.

The list of possible events is as follows:

- ❑ **None**
No anomaly.
- ❑ **Odd Turn Off**
UPS shutdown due to disconnection of the battery supply (during operation in battery mode or switching on).
- ❑ **Memory Error!**
Error in the UPS internal memory. **Contact your Service Centre.**
- ❑ **Battery Limit**
UPS shutdown due to complete batteries discharge caused by a prolonged absence of mains or attempt to switch on the UPS in battery mode after a shutdown due to complete battery discharge.
- ❑ **Battery Charger**
Failure of the battery charger of one or more power boards.
- ❑ **Overload**
UPS shutdown due to overload during battery operation.
- ❑ **Long Overload**
Overload longer than 5 seconds while the UPS was operating in mains mode. The UPS switches to bypass mode and remains on bypass till the load returns within nominal range.
- ❑ **Neutral Wrong**
Error in input neutral connection during start up. After about 10 seconds the UPS switches off.
- ❑ **Neutral Wrong While Running**
Error in input neutral connection during operation. The UPS switches over to battery or it remains connected to the mains.
- ❑ **Modules Number**
Microprocessor is not able to define how many power modules are installed inside the UPS. **Contact your Service Centre.**
- ❑ **Programmed Battery Time Expired**
UPS shutdown at the end of the programmed *Maximum Time On Battery*.
- ❑ **Programmed Reserve Time Expired**
UPS shutdown at the end of the programmed *Maximum Time After Reserve Threshold*.
- ❑ **Earth Fault**
UPS shutdown due to the intervention of its internal electronic output differential device, which revealed a current leakage towards the earth.
- ❑ **Load Waiting**
UPS shutdown due to a power fail while the UPS was in load waiting mode.
- ❑ **HV Bus Runaway**
UPS shutdown due to a loss of control of the internal BUS high voltage. **Contact your Service Centre.**
- ❑ **Output DC Level**
UPS shutdown due to the failure of one internal inverter. **Contact your Service Centre.**

- ❑ **Bad Wiring**
Error in UPS connection. Basically an attempt was made to feed the UPS through the output socket.
- ❑ **Output Plug Removed**
UPS shutdown due to the disconnection of input/output connector.
- ❑ **Hardware Fault :**
Failure of one or more of the electronic circuits on one or more of the power boards.
The possible faults (including combinations of the same) are listed below; in any event, **contact your Service Centre:**
 - **Unknown** Failure unknown
 - **Inverter** Inverter
 - **P.F.C.** Input voltage rectifier and booster
 - **Booster** Battery voltage booster
 - **Overheat** One power board or more has overheated
 - **Battery charger** Battery charger

3.4.3. Execution of Tests and Actions (“Actions and Test” menu)

Actions and tests that can be executed on the UPS or on the UPS server.

3.4.3.1. “Scheduler” menu

Scheduling options are the best way to optimise the use of the UPS and the load it is powering.

There are three scheduling categories:

- Shutdown/Restore: the switching off and subsequent (or not) restarting of the UPS
- Battery Test: battery test
- Autonomy Calibration Test: test for the calibration of UPS autonomy

The frequency of execution of each of the categories described above can be selected from the following:

- Once: executed once only on a set date and time
- Daily: executed every day at a set time
- Weekly: executed every week on a set day and at a set time

After setting the necessary data, select the “Save configuration” menu so that the modifications will take effect and be transferred to the UPS server, which will manage them independently.

It is not possible to alter schedules: they must be deleted and a new one created.

You can check the result of the execution of each individual scheduling by controlling the UPS server’s log file (if enabled).

N.B: UPS Switch off/Restart must be enabled for scheduling to work correctly (see “*UPS Server Configuration –Shutdown section*”).

3.4.3.2. “Battery Test” menu

This executes a test to verify the efficiency of the batteries inside the UPS. The type of response depends on the model of UPS connected.

3.4.3.3. "Autonomy Calibration Test" menu

This test is used to synchronise the data relating to the actual autonomy and battery capacity of the UPS with the UPS server.

In effect, when the software is installed for the first time, the UPS server is not capable of recognising the actual autonomy of the UPS and therefore uses the default setting of 5 minutes.

Executing this test (which should be repeated at least once every year) ensures this data is synchronised and updated to safeguard optimum operation of the UPS server.

If the load varies $\pm 10\%$ compared to the percentage of load applied at the time of the last test, the UPS Diag information panel will inform the user that the test should now be repeated.

Test procedure:

- The UPS switches over to battery power (the user is not informed of this) and starts its internal counter
- The UPS waits for the autonomy reserve signal
- The UPS restores normal operation
- The time this took is memorised along with the percentage of load

Notes on the procedure:

- The test must be executed with all the applied load switched on
- If the test is interrupted by the user, the new data for the autonomy will be the time taken until that moment
- At the end of the test, the batteries in the UPS will be discharged therefore the readings for "autonomy" and "battery capacity" will be zero.
- The UPS and the computer where the UPS server is installed must be left on until the batteries are fully recharged again.

3.4.3.4. "Execute Server Shutdown" menu

This enables execution of the shutdown of the computer connected to the UPS, provided this has been enabled in the configuration of the UPS server.

3.4.4. Setting the UPS parameters ("UPS Setup" menu)

UPS set-up is the system used to alter its operating parameters and enable certain special functions.

If a password has been specified during the configuration of the UPS server, it must be entered in order to access this type of functions.

The set-up window is divided into categories so that options are grouped together in a logical fashion.

3.4.4.1. "Input Data Set" menu

Settings for the operating parameters relating to the UPS input.

Stabiliser Level

This is used to modify the stabiliser's centring value when the UPS is running on mains power.

Enable Neutral Sense

The neutral sensor is able to inhibit the operation of the UPS in circumstances where the neutral potential shifts excessively from that of earth. During installation, it is useful for verifying that the power supply plug has been inserted correctly into the power outlet and will block operation in case of error. To start the UPS, simply invert the plug and switch it back on. This function will be inhibited if this option has been disabled.

- ❑ **Ignore Neutral Sense while running**
If this function is enabled, the UPS is allowed to ignore any excessive shift of the neutral potential away from earth and will only provide an acoustic warning signal (the UPS would normally switch over to battery power until fully discharged and then switch off).
- ❑ **Enable PLL**
Normally, the UPS will tolerate fluctuations in input frequency within certain limits. If this parameter is disabled, the UPS will accept any input frequency but still supply the nominal output frequency of 50 Hz (or 60 Hz).
- ❑ **Extend PLL lock range**
This specifies whether the UPS must extend the range of mains frequencies accepted (refer to the UPS instructions manual for further details). This function is only operational if the “*PLL enabled*” function has been enabled).

3.4.4.2. “Output Data Set” menu

Settings for the operating parameters relating to the UPS output.

- ❑ **Voltage [V]**
This is used to set the output voltage for the UPS (within a pre-determined range).
- ❑ **Frequency**
This parameter can be used to set the output frequency of the UPS to either 50 Hz or 60 Hz. If the *PLL enabled* parameter is set, the input will also be synchronised to accept the same frequency.
- ❑ **Mains Frequency Autoselect**
This is used to automatically set the input/output frequency of the UPS according to the power supply line.
- ❑ **Enable Bypass**
This option is used to enable automatic UPS management of the bypass.
Disabled bypass mode should only be used under special circumstances as the bypass will never enter operation with the possibility of UPS shutdown should there be an overload or internal failure.
- ❑ **Forced Bypass**
This is used to switch the bypass on permanently or to leave its management to the UPS (if the “*Bypass enabled*” function has been enabled).
This function should only be used in special circumstances as the UPS and the load connected will immediately switch off if there is a power failure.
- ❑ **Bypass Dip Speed**
This option is used to set the speed for the intervention of the automatic bypass.
- ❑ **OFF Line Mode**
This is used to select the UPS operating mode (only available for on-line UPS):
 - No: the UPS operates like a normal on-line UPS
 - Yes: the UPS goes into bypass and behaves like a non-stabilised switchover UPS, with mains efficiency of around 99%
- ❑ **Load Waiting Mode**
This is used to enable or disable the automatic switching on/off function of the UPS so that it operates according to the switching on and switching off of the connected load.
- ❑ **Load Waiting Threshold [W]**
This is to set the power threshold so that the UPS will go into stand-by below this limit (if the *Load Waiting Mode* function has been enabled) due to the connected load being switched off.

3.4.4.3. "Battery Data Set" menu

Used for setting the operating parameters relating to the batteries inside the UPS.

❑ **Automatic Battery Thresholds**

The two thresholds relating to the batteries ("*Reserve Threshold*" and "*Exhaust Threshold*") are the collating data used by the UPS to establish the status of the charge of the batteries.

These thresholds can be managed automatically by the UPS by way of its *Automatic* setting (when the connected load varies, these thresholds will also vary) or can be given permanent voltage settings by the user by way of the *Fixed* setting.

If 'fixed' settings are preferred, both thresholds can be set within predetermined limits:

- Reserve Threshold: below this threshold, the UPS will indicate that the batteries are low (Low Battery).
- Exhaust Threshold: below this threshold, the UPS will switch off due to fully discharged batteries.

❑ **Automatic Battery Test at UPS start-up**

This enables the execution of a battery test each time the UPS is switched on, provided mains power is present (does not apply after switching off due to end of autonomy).

❑ **Max Time on Battery**

If this function is enabled, it allows a maximum time to be specified for the UPS to run on battery power. At the end of the set time, the UPS will automatically switch off unless the mains power supply has been restored. If the "*Autorestart enabled*" option has been enabled, the UPS will automatically switch back on when mains power is restored.

❑ **Max Time after Reserve**

If this function is enabled, it allows a maximum time to be specified for the UPS to run in its autonomy reserve. At the end of this time, the UPS will switch off even if the mains power supply has been restored in the meantime. If the "*Autorestart enabled*" option has been enabled, the UPS will automatically switch back on when mains power is restored.

❑ **Enable Autorestart**

If this function is enabled, the UPS can be set so it will automatically switch back on when the mains power supply has been restored if it switched off because of the complete discharging of its batteries or due to the settings for "*Max Time on Battery*" and "*Max Time after Reserve*" parameters.

3.4.4.4. "Buzzer Set" menu

This is used to silence in a non-permanent manner ("*Mute*") or restore ("*Unmute*") the acoustic warning signals provided by the UPS.

3.4.4.5. "UPS Clock Set" menu

This is used to set the date and the time of the clock inside the UPS.

3.4.4.6. "UPS History Reset" menu

This is used to delete the history of the batteries, i.e.:

- Inverter operating time
- UPS interventions
- Battery full discharges

This function should only be used after the batteries have been replaced or after contacting the Customer Service Centre because deletion of this information could jeopardize the rapid diagnosis of UPS problems.

3.4.4.7. "Events List Reset" menu

This is used to delete the list of events stored in the UPS memory.

This function should only be used after maintenance by an authorised service technician or after contacting the Customer Service Centre because deletion of this information could jeopardize the rapid diagnosis of UPS problems.

3.5. System Shutdown

The shutdown command used for all the Linux distributions is as follows:

```
/sbin/init 0
```

Should use of a different command be required, the shutdown scripts must be modified, for UPS Server:

```
/usr/metasystem/upscomm/script/system/lcldown.sh
```

and for RS System:

```
/usr/metasystem/upscomm/script/system/rsdown.sh
```

Please note: as shutdown is a process that must be concluded as rapidly as possible, it is important to avoid the inclusion of programmes in this script.

4. Customisation of messages to users

The messages sent to users or by e-mail are contained in a file and can be modified at will.

A message file is customised by following the steps below:

- ✓ Close all open modules of UPS Communicator.
- ✓ Use a normal ASCII editor to edit the *<language>.msg* file (where *<language>* stands for the language currently in use) contained in *"/usr/metasystem/upscomm/Languages"*.

The messages file supports certain parameters used to customise the text or to provide more detailed information:

| | |
|---------------|---|
| #SERVER# | Name of the computer interfaced to the UPS. |
| #LOCATION# | Location of the UPS / computer (if specified in the configuration). |
| #UPSNAME# | UPS model. |
| #COMPORT# | Serial port used by the computer. |
| #TIMELEFT# | Actual remaining time, shown in minutes, before the start of shutdown. |
| #LISTENPORT# | IP port used by the server for communications with the monitoring client. |
| #DOWNWARNING# | Remaining time (minutes) before programmed shutdown. |
| ^ | Return (CR + LF). |

5. RS232 connection cables

5.1. Harviot 550

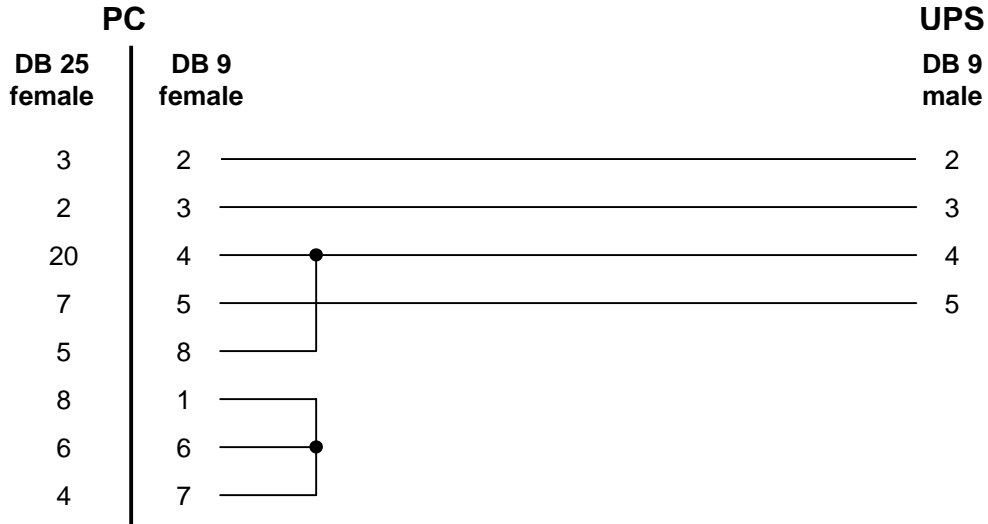

5.2. Niky 400, 600, 850

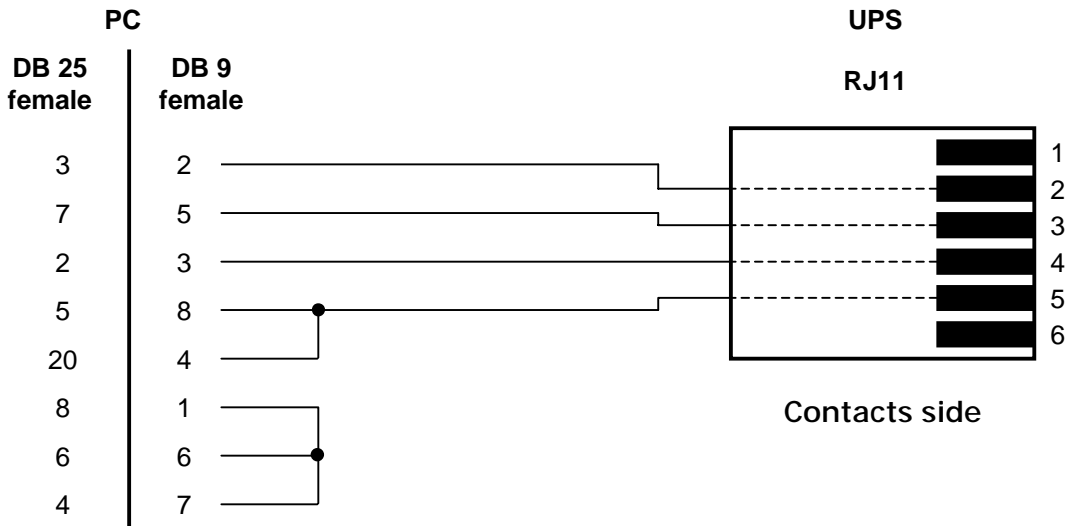

5.3. Niky 450, 650, 900

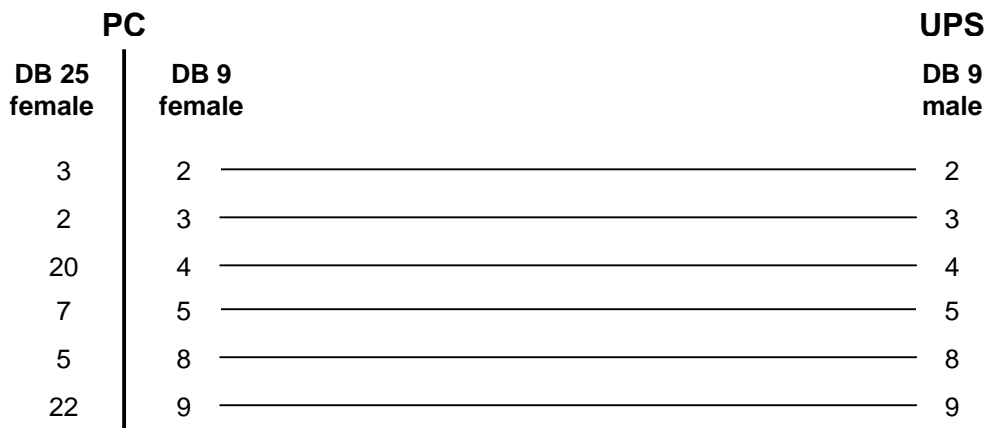

5.4. Niky 1100, 1500, 1800

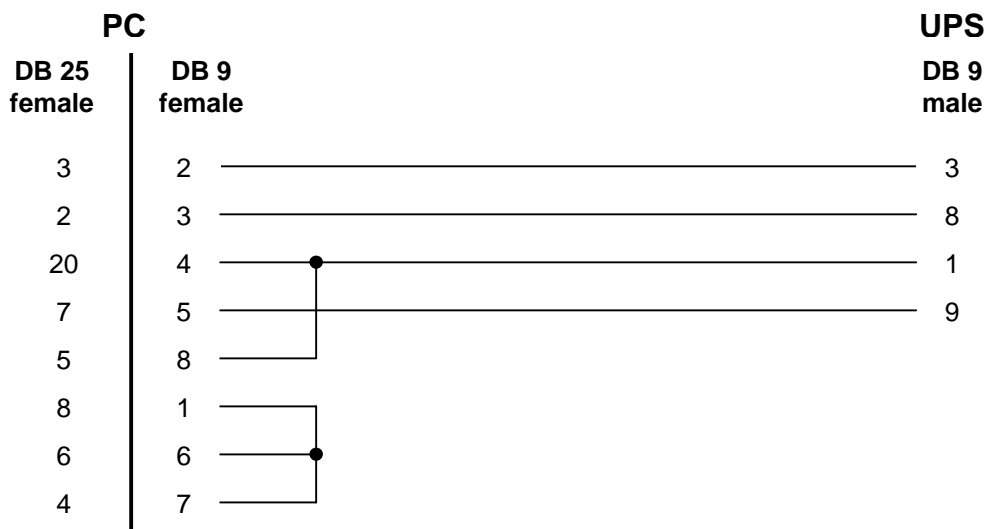

5.5. All others models

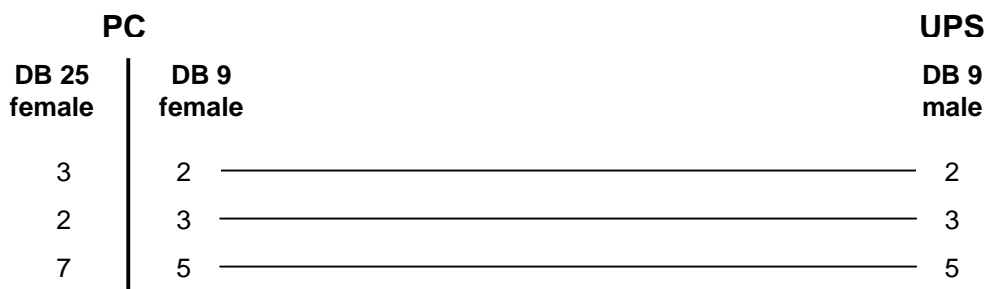

6. F.A.Q.

6.1. General Topics

Q: My computer won't switch on automatically when the UPS switches back on.

A: There are several factors that could affect the automatic switch-on of your computer. The main causes are listed below:

- ❑ In your computer's bios, the option "automatic switch on when power restored" hasn't been enabled (the exact wording varies from bios to bios, so consult your computer's manual for this).
 - ❑ Some motherboards will not allow the computer to be switched back on if the shutdown caused it to physically switch off (power down). To solve the problem, at the end of the shutdown procedure you have to get display of the message "It's now safe to switch off your computer" (consult the manual for your operating system for further details on how this modification is done).
 - ❑ The automatic switch on function has not been implemented: try updating the computer's bios.
 - ❑ Consult the F.A.Q. in the Windows section for issues connected to Windows 2003.
-

Q: If I shut down when the serial cable is connected, the computer reboots instead of switching off.

A: This problem only applies to UPS using a complete pin-to-pin cable: open one of the two connectors on the serial cable and cut all the wires that are not needed for communications (consult chapter "5. RS232 connection cables" – section "5.4. All other models").

6.2. Windows

Q: Windows 2003: the computer completes shutdown, switches off (power down) but does not automatically switch back on when the UPS switches back on.

A: This could be caused by various factors:

- ❑ Check the "General Topics" section in the F.A.Q.
- ❑ Windows 2003 contains a bug which does not allow you to set a shutdown preventing the physical switching off of the computer. Service Pack 1 should resolve this problem.

6.3. Linux

Q: When I try to run the installation programme, I get the following error message:
runtime error - segmentation fault at address xxxxxx

A: Some versions of kernel 2.6.x have a problem in managing virtual memory so you have to enable the "legacy VA Layout". This is done as follows:

- ❑ Edit the file /etc/sysctl.conf and add the following parameter: `vm.legacy_va_layout = 1`
- ❑ Restart the computer

7. Customer Service

Please write to the following addresses or phone us if you require any further information or in case of doubt:

Meta System S.p.A.
Via Galimberti, 8
42100 Reggio Emilia – Italy
<http://www.metasystem.it>

for queries regarding sales and marketing issues:

Tel. (+39) 0522 364111
e-mail: info@metasystem.it

for technical queries:

Tel. (+39) 0522 364111
e-mail: assistenza.ups@metasystem.it